

# Product data sheet

## Characteristics

# TM3DM24R

Discrete I/O module, Modicon TM3, 24 IO (16 inputs, 8 relay outputs, screw) 24 VDC



Product availability: Non-Stock - Not normally stocked in distribution facility

Price\*: 199.00 USD



### Main

Range of Product	Modicon TM3
Product or Component Type	Discrete I/O module
Range Compatibility	Modicon M241 Modicon M251 Modicon M221 Modicon M262
Discrete input number	16 input IEC 61131-2 Type 1
Discrete input logic	Sink or source (positive/negative)
Discrete input voltage	24 V
Discrete input current	7 mA input
Discrete output type	Relay normally open
Discrete output number	8
Discrete output logic	Positive or negative
Discrete output voltage	24 V DC relay output 240 V AC relay output
Discrete output current	2000 mA relay output

### Complementary

Discrete I/O number	24
Current consumption	5 mA 5 V DC via bus connector at state off) 0 mA 24 V DC via bus connector at state on) 0 mA 24 V DC via bus connector at state off) 65 mA 5 V DC via bus connector at state on)
Discrete input voltage type	DC
Voltage state 1 guaranteed	15...28.8 V input
Current state 1 guaranteed	>= 2.5 mA input)
Voltage state 0 guaranteed	0...5 V input
Current state 0 guaranteed	<= 1 mA input)
Input impedance	3.4 kOhm
Response time	4 ms (turn-on) 4 ms (turn-off)

Maximum current per output common	7 A
Mechanical durability	20000000 Cycles
Minimum load	10 MA 5 V DC relay output
Local signalling	1 LED per channel (green) for I/O state
Electrical connection	17 x 1.5 mm <sup>2</sup> removable screw terminal block pitch 3.81 mm for inputs 11 x 1.5 mm <sup>2</sup> removable screw terminal block pitch 3.81 mm for outputs
Maximum cable distance between devices	Unshielded cable <98.43 ft (30 m) regular input
Insulation	Between input and internal logic 500 V AC Non-insulated between inputs Between input groups and output groups 1500 V AC Between open contact 750 V AC Between output and internal logic 500 V AC Non-insulated between outputs
Marking	CE
Mounting support	Top hat type TH35-15 rail conforming to IEC 60715 Top hat type TH35-7.5 rail IEC 60715 plate or panel with fixing kit
Maximum Height	3.54 In (90 mm)
Maximum Depth	3.33 In (84.6 mm)
Maximum Width	1.69 In (42.9 mm)

## Environment

Standards	EN/IEC 61131-2 EN/IEC 61010-2-201
Product Certifications	CULus C-tick
Resistance to electrostatic discharge	8 KV in air EN/IEC 61000-4-2 4 KV on contact EN/IEC 61000-4-2
Resistance to electromagnetic fields	9.14 V/M (10 V/m) 80 MHz...1 GHz EN/IEC 61000-4-3 2.74 V/M (3 V/m) 1.4 GHz...2 GHz EN/IEC 61000-4-3 0.91 V/M (1 V/m) 2 GHz...3 GHz EN/IEC 61000-4-3
Resistance to magnetic fields	98.43 A/M (30 A/m) 50/60 Hz EN/IEC 61000-4-8
Resistance to fast transients	1 KV I/OEN/IEC 61000-4-4 2 KV relay outputEN/IEC 61000-4-4
Surge withstand	2 KV output common mode EN/IEC 61000-4-5 1 KV input common mode EN/IEC 61000-4-5
Resistance to conducted disturbances	10 V 0.15...80 MHz EN/IEC 61000-4-6 3 V spot frequency (2, 3, 4, 6.2, 8.2, 12.6, 16.5, 18.8, 22, 25 MHz) Marine specification (LR, ABS, DNV, GL)
Electromagnetic emission	Radiated emissions 40 dBµV/m QP class A 10 m)30...230 MHz EN/IEC 55011 Radiated emissions 47 dBµV/m QP class A 10 m)230...1000 MHz EN/IEC 55011
Ambient Air Temperature for Operation	14...95 °F (-10...35 °C) vertical installation 14...131 °F (-10...55 °C) horizontal installation
Ambient Air Temperature for Storage	-13...158 °F (-25...70 °C)
Relative humidity	10...95 %, without condensation in operation) 10...95 %, without condensation in storage)
IP degree of protection	IP20 with protective cover in place
Pollution degree	2
Operating altitude	0...6561.68 ft (0...2000 m)
Storage altitude	0.00...9842.52 Ft (0...3000 m)
Vibration resistance	3.5 mm 5...8.4 Hz DIN rail 3 gn 8.4...150 Hz DIN rail 3.5 mm 5...8.4 Hz panel 3 gn 8.4...150 Hz panel
Shock resistance	15 gn 11 ms

### Ordering and shipping details

Category	22533 - M2XX PLC & ACCESSORIES
Discount Schedule	MSX
GTIN	03606480611544
Nbr. of units in pkg.	1
Package weight(Lbs)	1 Lb(US) (0.45 kg)
Returnability	Yes
Country of origin	TW

### Packing Units

Unit Type of Package 1	PCE
Package 1 Height	2.97 In (7.551 cm)
Package 1 width	4.21 In (10.686 cm)
Package 1 Length	5.06 In (12.849 cm)

### Offer Sustainability

Sustainable offer status	Green Premium product
California proposition 65	WARNING: This product can expose you to chemicals including: Lead and lead compounds, which is known to the State of California to cause cancer and birth defects or other reproductive harm. For more information go to <a href="http://www.P65Warnings.ca.gov">www.P65Warnings.ca.gov</a>
REACH Regulation	<a href="#">REACH Declaration</a>
REACH free of SVHC	Yes
EU RoHS Directive	Pro-active compliance (Product out of EU RoHS legal scope) <a href="#">EU RoHS Declaration</a>
Toxic heavy metal free	Yes
Mercury free	Yes
RoHS exemption information	<a href="#">Yes</a>
China RoHS Regulation	<a href="#">China RoHS Declaration</a>
Environmental Disclosure	<a href="#">Product Environmental Profile</a>
Circularity Profile	<a href="#">End Of Life Information</a>
WEEE	The product must be disposed on European Union markets following specific waste collection and never end up in rubbish bins.
PVC free	Yes

Dimensions

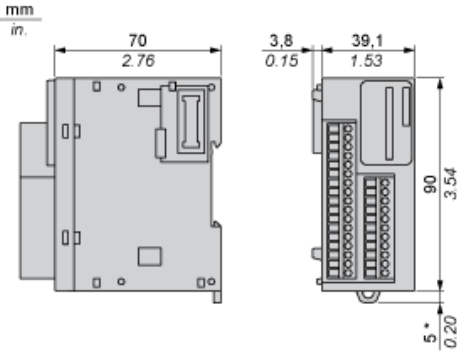

(\*) 8.5 mm/0.33 in. when the clamp is pulled out.

Spacing Requirements



Mounting on a Rail

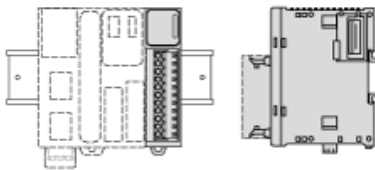

Incorrect Mounting

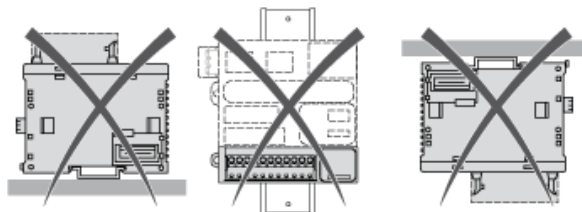

Mounting on a Panel Surface



(1) Install a mounting strip

# Mounting Hole Layout

mm  
in.

M4 x 6/8  
0.24/0.31

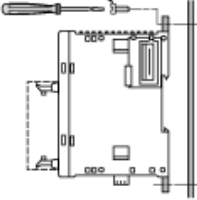

19.65  
0.77

2xØ4.3  
2xØ0.17

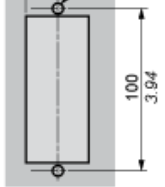

100  
3.94

Digital Mixed I/O Module (24-channel)

Wiring Diagram (Source)

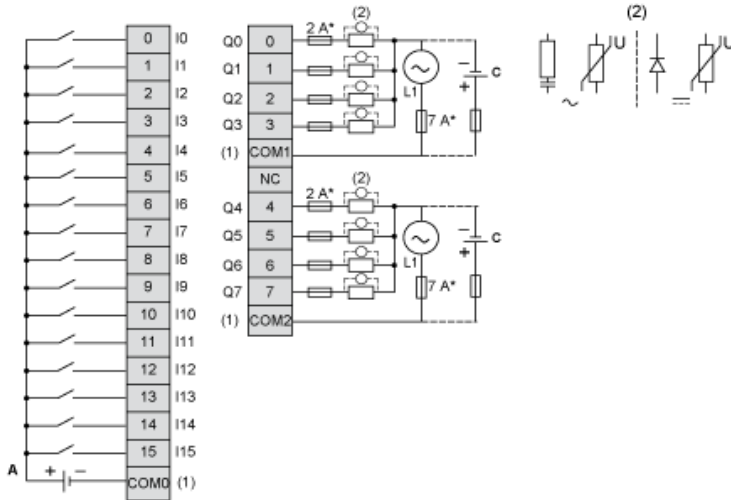

- (\*) Type T fuse
- (1) The COM0, COM1 and COM2 terminals are not connected internally.
- (2) To improve the life time of the contacts, and to protect from potential inductive load damage, it is recommended to connect a free wheeling diode in parallel with the load.
- (A) Sink wiring (positive logic)
- (C) Source wiring (positive logic)

Wiring Diagram (Sink)

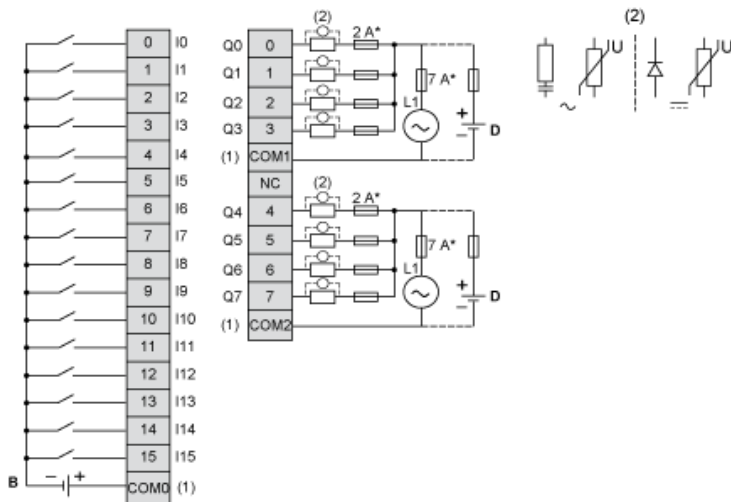

- (\*) Type T fuse
- (1) The COM0, COM1 and COM2 terminals are not connected internally.
- (2) To improve the life time of the contacts, and to protect from potential inductive load damage, it is recommended to connect a free wheeling diode in parallel with the load.
- (B) Source wiring (negative logic)
- (D) Sink wiring (negative logic)

Product Life Status : **Commercialised**